

DW SUBMERSIBLE DRAINAGE PUMP



2DW05
3DW100

Semi Vortex impeller design minimize the Clogging situation for maximum durability and maintaining pump performance. Built-in shaft mounted agitator prevents the “air lock” and reduces the clogging situation.

Application

Civil engineering, building sites, basements or other utility Pits, rainwater, mud water and high-viscosity fluid.

Specification

- Water temperature: up to 40°C
- PH: 6.5 to 8.5
- Power supply: single phase 230V ± 10%, 60Hz
- Insulation class: F
- Protection class: IP68
- Cable length: 8m
- Max water depth: 10m



Special features on request

- Other voltages

Performance curves & table

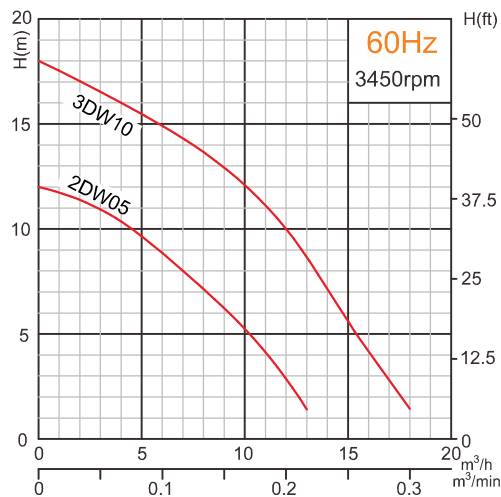

| Model (60Hz) | Outlet | Motor power | | Rated current (A) | | Rated capacity | | Rated head | Max capacity | | Max Head | Impeller Passage |
|--------------|--------|-------------|------|-------------------|--------|----------------|--------|------------|--------------|--------|----------|------------------|
| | mm | kW | HP | 1~115V | 3~230V | m³/h | m³/min | m | m³/h | m³/min | m | mm |
| 2DW05 | 50 | 0.4 | 0.55 | 5.8 | 2.9 | 7 | 0.12 | 8 | 12.6 | 0.21 | 12 | 6 |
| 3DW10 | 80 | 0.75 | 1 | 9.5 | 3.4 | 12 | 0.20 | 10 | 18 | 0.3 | 17/18 | 6 |

• FS: Three phase; FSM: Single phase; FSM...F: Single phase with Float switch



SUBMERSIBLE DRAINAGE PUMP DW

**2DW05
3DW100**

**2DW05
3DW100**

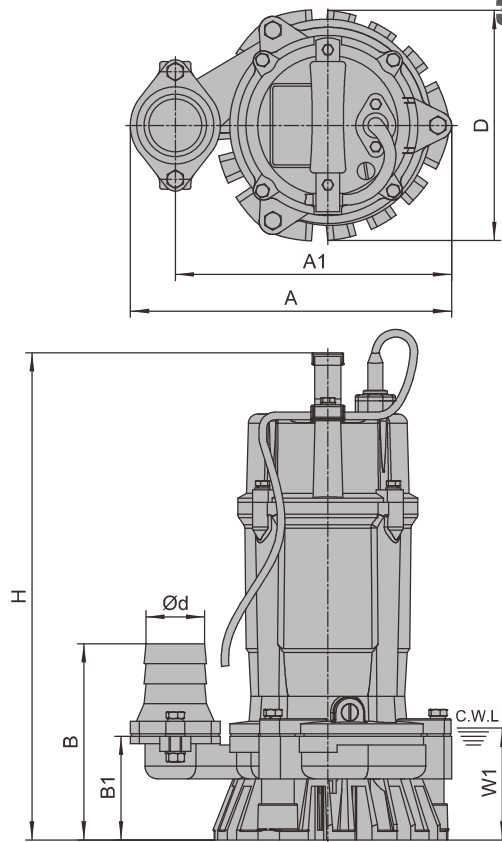
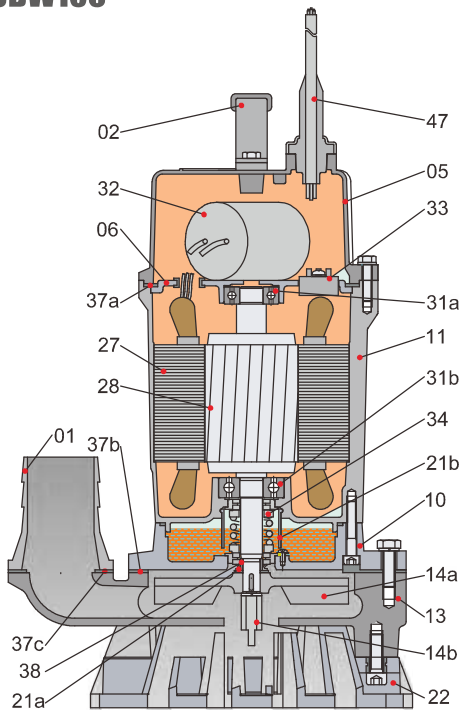

W1: Continuous running water level

Material of construction

| Item No. | Part name | Material | Item No. | Part name | Material |
|----------|------------------|----------------------|----------|-----------------|----------------------------|
| 01 | Hose coupling | Cast iron | 27 | Stator | |
| 02 | Handle | Rubber&steel | 28 | Rotor | Shaft:AISI420SS |
| 05 | Upper cover | Aluminum die casting | 31a | Bearing | Ball bearing |
| 06 | Up-Bearing house | Cast iron | 31b | Bearing | Ball bearing |
| 10 | Seal house | Cast iron | 32 | Capacitor | |
| 11 | Motor body | Aluminum die casting | 33 | Motor protector | |
| 13 | Pump body | Cast iron | 34 | Mechanical seal | Ceramic-Sic/Carbon-Ceramic |
| 14a | Impeller | Ductile iron | 37a | Gasket | NBR |
| 14b | Agitator | Stainless steel | 37b | Gasket | NBR |
| 21a | Sand guard | NBR | 37c | Gasket | NBR |
| 21b | Oil riser | LDPE | 38 | Shaft sleeve | AISI420SS |
| 22 | Seat assembly | PU | 47 | Cable | H07RN-F |

Dimensions & weights

| Model (50/60Hz) | d mm | A mm | A1 mm | B mm | B1 mm | D mm | H mm | W1 mm | N.W Kg | G.W Kg | Packing dimension mm |
|--------------------|---------|---------|----------|---------|----------|---------|---------|----------|-----------|-----------|-------------------------|
| 2DW05 | 50 | 237 | 201 | 157 | 84 | 185 | 365 | 85 | 13.5 | 14.5 | 405x255x255 |
| 3DW10 | 80 | 284 | 234 | 215 | 109 | 185 | 390 | 85 | 18 | 19 | 445x295x255 |